

ELYMER

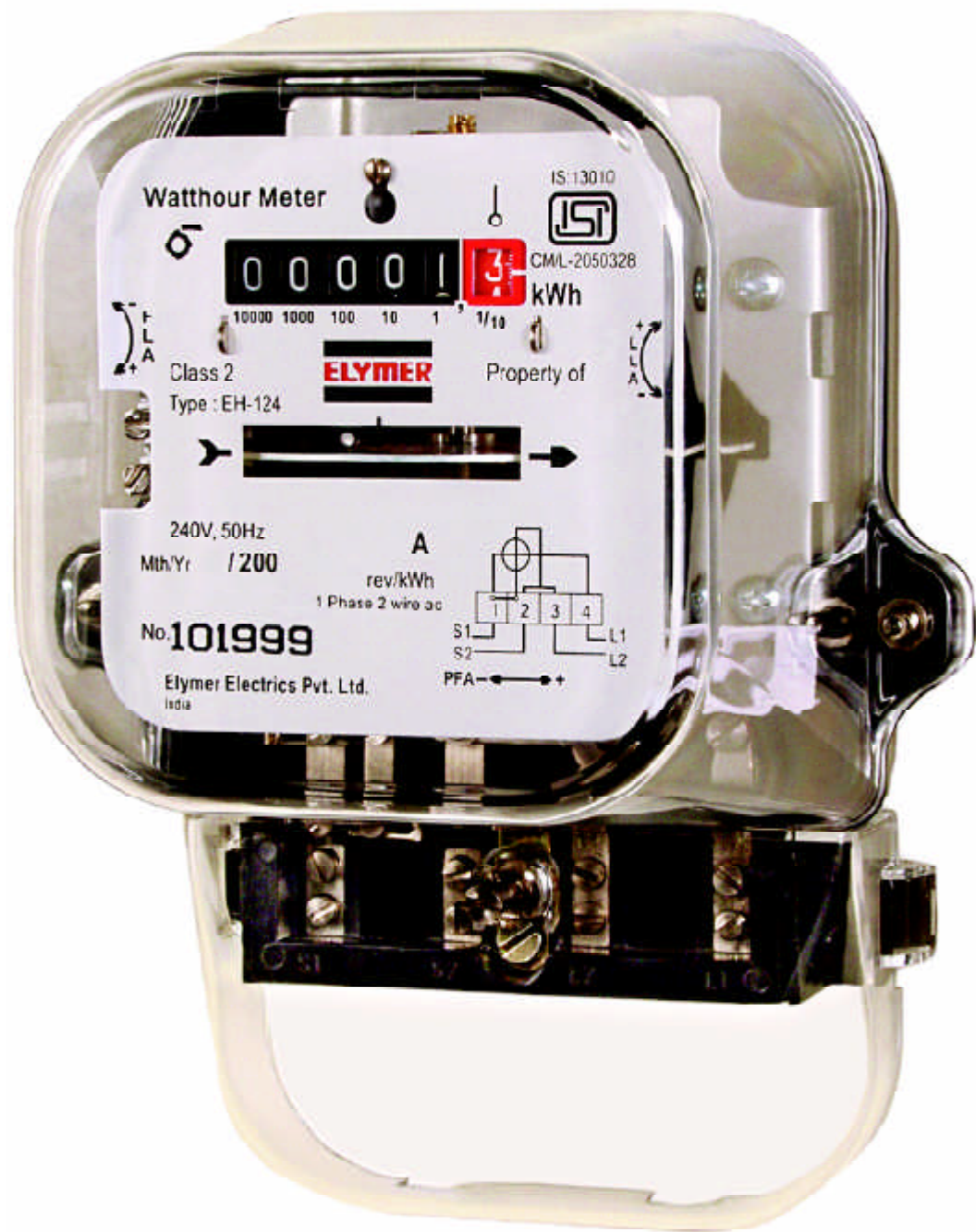

PRESENTATION

For over two decades, ELYMER group has led the manufacturing of watt-hour meters for domestic applications in India. With a present capacity of one million meters per annum, backed by the engineering expertise and commitment to excellence the group leads the metering industry in India.

Application

Elymer electromechanical electricity meters are suitable for measuring active energy (kWh)-

in single phase for direct connection upto 100A.

in three-phase four-wire networks at balanced or unbalanced load for direct connection upto 120A.

in three phase three or four wire networks for CT operated measurement at balanced or unbalanced load.

Elymer meters are designed and manufactured to ensure:

- measuring accuracy and stability
- safety against extreme environmental effects
- safety against electric shock hazards and spread of fire
- compatibility with the specific requirements of the various markets.

Specifications

All measuring and technical characteristics comply with requirements of IEC 521, IS:13010, and BS 5685, with their latest amendments, and various other national specifications.

The products have been certified at various test laboratories of national and international repute.

Application

The standard single phase meter is intended to measure active electrical energy in single phase, two wire networks.

They are available in various direct operating versions.

EH-124 2.5-10A 5-20A, 10-40A, 20-80A

EH-124/5 5-25A, 10-50A 20-100A

EH-124/6 5-30A, 15-90A

EH-124/8 10-80A

The standard meters are surface mounting bottom connected type.

M: Magnetic Suspension Bearing

U: Unidirectional Counter (without RR stop)

S: Short terminal cover

C: Larger digit drum size (6.9 x 3.7mm)

J: Jumping figure type counter (available with large digits only)

Cyclometer Register

The register is cyclometer type with six digit wheels moulded from self-lubricating acetal copolymer, dimensionally stable to wide temperature variations. The readings are shown in kWh with one decimal (or no decimal) without using any multiplication factor. The periphery of last drum is subdivided into 100 sections.

The low friction register does not require any kind of lubrication. The fictional torque of the register is negligible even at low loads and does not change with time.

The register framework is fastened to the meter frame duly guided for accurate placement, so that worm and worm wheel is properly engaged even when the counter is replaced.

The digit size of 5x3mm. Large digit size of 6.9x3.7mm is also available optionally.

Meters are fitted with a reverse running stop device with hardly discernible friction, having no effect on meter accuracy.

Physical and mounting dimensions (in mm)

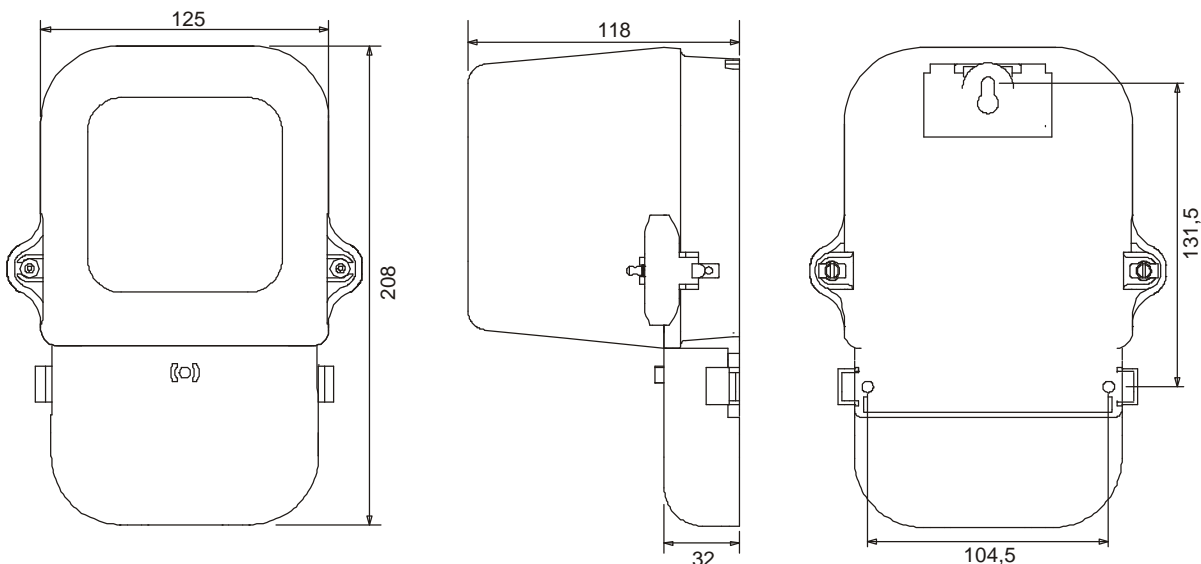

Rotor Mechanism

The rotor disc is made from high purity and high conductivity aluminium, is graduated in 100 divisions on its upper surface for accurate calibration and testing.

Removal and reassembly of the rotor disc assembly is simple without involving any alteration to the original positioning. The worm on the rotor spindle and worm wheel connecting to the cyclometer is made self lubricating long life polymer.

The direction of rotation is from left to right when viewed from the front of the meter.

Terminal Block

The terminal block is moulded from insulating non-hygroscopic flame retardant phenolic compound, highly resistant to creep current. It is fitted into the base, so that access to meter interior is not possible when the cover is on.

The incoming and outgoing terminals are made of solid brass, with two screws in each terminal to accept cables up to 16 mm² for and up to 40A and 50 mm² for and up to 100A.

The flashover and creep distances, between metal parts of individual circuits on one hand, and terminal and outside contact parts on the other, are large enough to assure high breakdown strength. The extended lower part of base protects terminal block against mechanical effects.

Braking Element

The high energy brake magnet functions independent of the position of the disk in the electromagnetic gap. It is made of four pole Alnico magnet with high coercivity die-cast in SiAl alloy, is securely fixed to steel meter frame, and is insensitive to external magnetic fields or an accidental short circuit.

Adequate temperature compensation is provided.

Accessible Adjustments

All calibration facilities are capable fine adjustment with adequate range.

1. **High load adjustment** by shunting the flux of the four pole magnet, which is rigidly fixed to the frame, and changing the braking torque on the disc.
2. **Low load adjustment** that balances the effect of the voltage circuit flux.
3. **Phase shift/Inductive load adjustment** varying the resistance of current flux shunt on a resistance strip.

Typical Load curves

— $Un \cos \phi = 1$
 — $Un \cos \phi = 0.5$

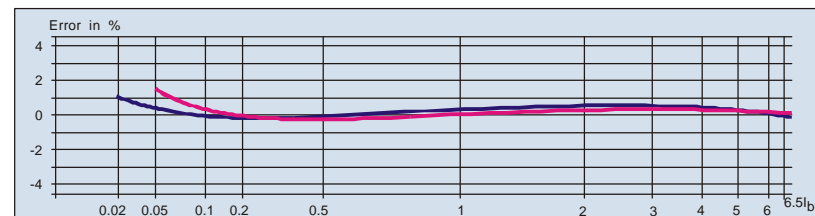

Effects of voltage variations

— $Ib \cos \phi = 1$
 — $Ib \cos \phi = 0.5$

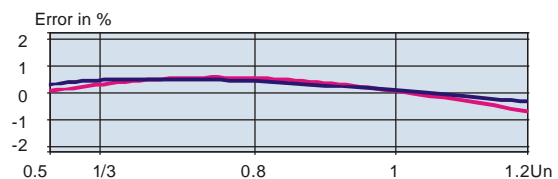

Effects of frequency variations

— $Ib \cos \phi = 1$
 — $Ib \cos \phi = 0.5$

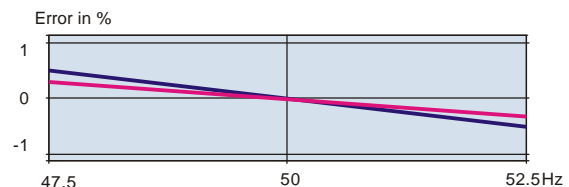

Effects of temperature variations

— $Ib \cos \phi = 1$
 — $Ib \cos \phi = 0.5$

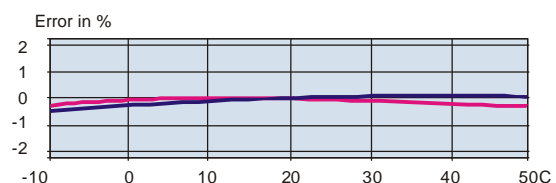



TECHNICAL INFORMATION

Reference Voltage (U_n)	230/240V
Frequency	50 Hz ($\pm 5\%$)
Rated Thermal Current	$> 130\%$ of I_{max}
Accuracy Class	Class 2
Starting Current	0.5% of I_b , at U_n and unity pf
Voltage Creep	No creep at 75% and 120% U_n
Rotor Weight	19.5 g (with jewel bearing) 22.6 g (with suspension bearing)
Torque	$I_{max}/I_b = 4;$ > 4.6 gm-cm at I_b $I_{max}/I_b = 5, 6;$ > 4.3 gm-cm at I_b $I_{max}/I_b = 8;$ > 3.9 gm-cm at I_b
Speed of Rotor	$I_{max}/I_b = 4, 5;$ 15 rpm $I_{max}/I_b = 6;$ 12 rpm $I_{max}/I_b = 8;$ 9 rpm
Voltage circuit loss	< 0.98 W, 3.9 VA
Current Circuit loss	0.31 VA (0.24 W) at rated current
Dielectric Test	50 Hz, 2500 V P_c
Insulation Resistance	More than 20 M-ohm at 500Vdc
Voltage Shock	10 KV Impulse Voltage, 1.2/50
Adjustment Range	
5%, Upf	more than 10%
$I_{max}/2$, Upf	more than 8%
$I_{max}/2$, 0.5 pf	more than 2%
Meter Weight	1.08 kg (approx.)
Relevant Standard	IS:13010, IEC 521, BS 5685

Elymer Electrics Pvt. Ltd.

Off. 6 Alipore Road, Civil Lines,
Delhi 110054 (India)
Ph. (011) 7662351
Fax. (011) 7662355
elymer@vsnl.com, elymer@eth.net
www.elymer.com

Works 7 Tilak Nagar Industrial Area
New Delhi 110018
Ph. (011) 5191440
Fax. (011) 5116279